



International Energy Agency

ECBCS

Energy Conservation in Buildings and Community Systems Programme

June 2008
Issue

news 47

Fuel Cell and Cogeneration Project Publishes Final Report

Ian Beausoleil-Morrison, Annex 42 Operating Agent

ECBCS Annex 42 was established in 2003 to examine the emerging technology of residential cogeneration, and officially closed in 2008. Annex 42, whose working title was “FC+COGEN-SIM: The Simulation of Building-Integrated Fuel Cell and Other Cogeneration Systems,” was a task-shared collaborative research project involving 26 organizations from 10 countries.

Residential cogeneration (also known as micro-cogeneration and small-scale combined heat and power) is an emerging technology with a high potential to deliver energy efficiency and environmental benefits. The concurrent production of electrical and thermal energy from a single fuel source can reduce primary energy (PE) consumption and associated greenhouse gas (GHG) emissions. Reductions in combustion by-products such as nitrogen oxides, sulphur dioxide, and hydrocarbons are also a possibility. The distributed generation nature of the technology also has the potential to reduce electrical transmission and distribution inef-

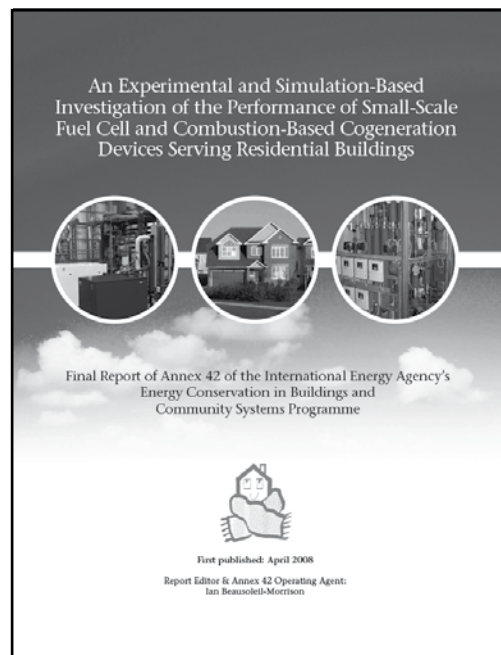

ALSO IN THIS ISSUE:

- Energy Conservation in Buildings and Heat Pump Use 3
- Advanced Building Ventilation - AIVC Conference 4
- Transition to Near-Zero Primary Energy Use - ECBCS Role 5
- Prefabricated Systems for Low Energy Renovation 6
- Case Study: Retrofit of a Laboratory Building 8
- Workshop - Trends in National Building Ventilation 10
- Forthcoming ECBCS Technical Synthesis Reports 12

ECBCS
Strategic Plan
to Year 2012
Page 5

iciencies, and alleviate utility peak demand problems.

Annex 42 focused on natural-gas-fired cogeneration devices with electrical outputs that varied from under 1 kW to 15 kW. The following four technologies were considered:

- proton exchange membrane fuel cells (PEMFC), also referred to as polymer electrolyte membrane fuel cells;
- solid oxide fuel cells (SOFC);
- Stirling engines (SE); and
- internal combustion engines (ICE).

Annex 42 conducted a review of these four technologies for residential cogeneration. The principles of their operation were described and information on manufacturers and commercially available products was assembled based on existing published data as well as unpublished material derived from the Annex 42 participants. This review (available via the ECBCS web site) indicated a lack of detailed information on performance characteristics. In many sources, the reference point for efficiencies (lower or higher heating value of the fuel) was not mentioned, nor was information provided on part-load operation and parasitic energy losses. This underlined the need for further investigation of residential cogeneration technologies. The review clearly demonstrated that the residential cogeneration industry is in a rapid state of development and flux. Indeed, there were numerous acquisitions, business failures, and restructurings of companies within the industry over the four-year period of Annex 42's work. The market remains immature, but interest in the technologies by manufacturers, energy utilities, and government agencies remains strong.

Small-scale PEMFC, SOFC, SE, and ICE devices have only modest fuel-to-electrical conversion efficiencies: some existing prototypes have efficiencies as low as 5% (net AC electrical output relative to the source fuel's lower heating value, or LHV). Although SOFC technolo-

gies have the potential to deliver electrical efficiencies as high as 45%, these levels have not yet been realized in integrated small-scale cogeneration systems. Given that these electrical efficiencies are relatively low compared to combined-cycle central power plants (the state-of-the-art for fossil-fuel-fired central power generation), it is imperative that the thermal portion of the cogeneration device's output be well utilized for space heating, space cooling, and/or domestic hot water (DHW) heating. If this thermal output cannot be well utilized in the residence, then residential cogeneration technologies cannot be expected to deliver a net benefit relative to the best available central generation technologies.

However, the analysis of thermal energy utilization in buildings is complicated by strong coupling between the cogeneration unit, other heating, ventilation and air conditioning (HVAC) components, and the building's thermal and electrical demands. These system integration issues lead to the need to use whole-building simulation programs to facilitate the analysis of residential cogeneration.

These are the factors that motivated the formation of Annex 42, the specific objectives of which were to develop simulation models that advance the design, operation, and analysis of residential cogeneration systems, and to apply these models to assess the technical, environmental, and economic performance of the technologies. These objectives were accomplished by developing and incorporating models of cogeneration devices within existing whole-building simulation programs. These models are more detailed than the simple performance map methods that have been previously applied to assess residential cogeneration and that cannot accurately treat the thermal coupling to the building and its HVAC system. However, the Annex 42 models are more simplified than detailed process flow methods, which would be inappropriate for use in whole-building

simulation as their computational burden precludes their application when using time-varying boundary conditions.

Annex 42 carried out three main tasks:

- A review of the current status of residential cogeneration technologies and characterisation of occupant-driven electrical and DHW usage patterns.
- Developed models for residential SOFC, PEMFC, SE, and ICE devices and implemented these into existing whole-building simulation programs. Experimental work was also conducted on prototype and early-market devices, and these data were used to calibrate the models (i.e., establish their input data). The emphasis was placed on validating the models and verifying the accuracy of their implementations.
- Assessed the technical, environmental, and economic performance of selected cogeneration applications. This focused on applying the above models and the occupant-driven electrical and DHW usage patterns from the review.

A 70-page final report in booklet format (available for download through the ECBCS web site) summarizes the research conducted by Annex 42 and provides some of its key findings. Also available for download from the ECBCS web site are 12 detailed reports and accompanying data that provide the full details on all aspects of Annex 42's research. Each of these 12 reports is referenced and described in the 70-page booklet.

Section I of the 70-page booklet introduces the work on Annex 42. This is followed by Section II which describes the review of non-HVAC, occupant-driven electrical and DHW usage profiles. (Electronic versions of these profiles are available for download.) Sections III through V discuss model development. Section III provides an overview of the models and their implementation

Energy Conservation in Buildings and Heat Pump Use

Jean Lebrun, Operating Agent for Annex 48 and Executive Committee Member for Belgium

Jean Lebrun describes the Technical Day held at the 62nd ECBCS Executive Committee Meeting, held in Brugge, Brussels on 15-16 November 2007.

The Meeting

This was a common technical briefing of the Executive Committees of the two Implementing Agreements of the International Energy Agency, the Energy Conservation in Buildings and Community Systems (ECBCS), and the Heat Pump Programme (HPP).

The meeting was organized in Brussels by the Directorate-General for Energy of the Belgian Federal Public Service (FPS), in cooperation with the Thermodynamics Laboratory of the University of Liège, and was chaired by Sophie Hosatte, chair of the Heat Pump Programme and Markku Virtanen, vice-chair of ECBCS.

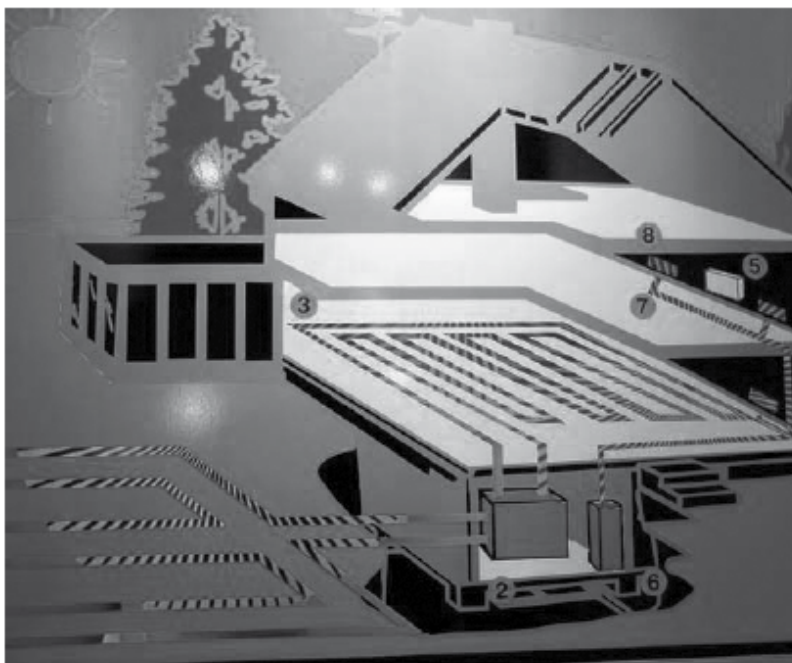

Continued on page 11

into existing whole-building simulation programs (ESP-r, Energy Plus, TRNSYS, and IDA-ICE). Section IV addresses the calibration of these models using the experimental data gathered by Annex 42. Section V discusses the methods used to empirically validate the models and to verify their implementation into the whole-building simulation programs using comparative testing. Section VI discusses the work to assess the performance of residential cogeneration systems. It summarizes the existing literature, demonstrates how the Annex 42 models can be applied to examine the potential of residential cogeneration, and provides key findings from the simulation studies conducted by Annex 42. Readers

interested in the performance of residential cogeneration systems could jump immediately to Section VI, although the information treated in sections II through V provide important context and methodology that form the basis of the results presented in Section VI. Finally, the booklet concludes with Section VII, which describes the lessons learned by Annex 42 and provides recommendations for future research.

Annex 42 culminated with the 1st International Conference and Workshop in Micro-Cogeneration that was held in Ottawa (Canada) in April and May, 2008. Many of the research results of Annex 42, as well as those from researchers outside Annex 42 were presented and debated. Discussions are cur-

rently ongoing for the formation of a follow-on ECBCS Annex to continue the study of this emerging field that has much potential to reduce energy consumption and associated environmental emissions in the buildings sector.

Further information

www.ecbcs.org/annexes/annex42.htm

AIVC Annual Conference

Japan – Kyoto International Conference Centre

14-16 October 2008

Advanced Building Ventilation and Environmental Technology for Addressing Climate Change Issues

Scope

In 2008, when the target period of the Kyoto Protocol begins, the 29th AIVC Conference will be held at Kyoto International Conference Centre, Kyoto, Japan, where the protocol was negotiated in December 1997. The conference will provide a valuable opportunity for researchers and engineers worldwide to convene for “Advanced building ventilation and environmental technology for addressing climate change issues”.

The increase of carbon dioxide due to energy use in buildings is a common issue for most countries in the world. Above all, it is expected that the energy use for indoor environmental control including ventilation, heating and air-conditioning must be substantially reduced to mitigate the global warming issue, while there are increasing demands for better indoor health and comfort.

The AIVC (Air Infiltration and Ventilation Centre) founded in 1979 under the IEA Implementing Agreement ECBCS (Energy Conservation for Building and Community Systems), is the most recognised portal for technological information on ventilation. The AIVC Conference has been held every year. For the 29th AIVC Conference, in collaboration with ECBCS, papers are to be presented for the following research



and development topics:

- Natural Ventilation
- Mechanical Ventilation
- Hybrid Ventilation
- Air Filtering
- HVAC System for Non-Residential Building
- Heating and Air-Conditioning for Residential Building
- Thermal Environment
- Standard and Regulation for Ventilation and HVAC
- Control Technology
- Commissioning
- Integration of Building Envelope and Services
- Envelope Air Tightness
- Condensation Prevention
- Energy Retrofitting
- Computer Simulation
- Post Occupancy Evaluation and Surveys
- Case Study Building
- Air Distribution

Location

Kyoto prefecture is at the centre of the Japanese archipelago. It has been the centre of Japan's long history and rich culture for over 1200 years and is Japan's biggest tourist destination.

Conference Secretariat

IIBH (Institute of International Harmonisation for Building and Housing)

Website: www.aivc2008.jp

Email: info@aivc2008.jp

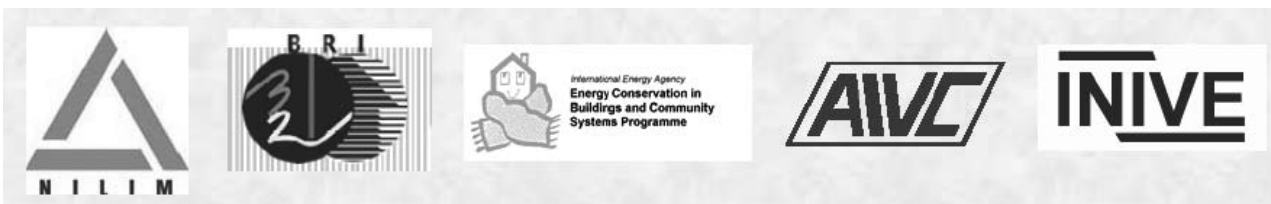

ECBCS R&D Contributes to Transition to Near-Zero Primary Energy Use & Carbon Emissions from the Built Environment

The new ECBCS Strategic Plan sets the research agenda to 2012

The newly approved ECBCS Strategic Plan looks forward for the next five years to 2012 and aims its R&D to lead the transition of the building sector to near-zero primary energy use and carbon emissions.

Any new sustainable solution needs to fulfil the demands of ecological (energy and environment), economic (market and business) as well as social sustainability (end-users). The final goal is a solution that fulfils all three criteria in a balanced way.

Mission

The mission of ECBCS is, “to develop and facilitate the integration of technologies and processes for energy efficiency and conservation into healthy, low emission, and sustainable buildings and communities, through innovation and research.”

Barriers and Drivers

In achieving its mission, ECBCS needs to take account of the following barriers and drivers:

- The increasing scarcity of natural resources versus population growth
- Legislation
- Human health and wellbeing
- Urbanisation
- Lack of skilled resources
- Rise in living standards in developing countries - The 80% of the world's population now living in developing countries will soon require the same quality of life as the people of the industrialised countries.

To move towards an energy efficient and environmentally sustainable building sector and community, tools still need to be developed. For effective energy efficient communities, three actions are critical:

1. Reduce the heating, cooling and lighting loads to a minimum.
2. Use the exergy of renewable and waste energy sources as effectively as possible.
3. Make fossil fuel use as effective and clean as possible.

The resulting solutions should also be user friendly, so that people would automatically be able to use the technology correctly, and not be able to cause critical defects to the system. The final goal should be integrated and performance-based solutions for energy efficient and environmentally friendly buildings and communities that support sustainability and produce carbon-free energy according to demand.

Strategies

The R&D strategies are derived from research drivers, national programs within IEA countries, and the IEA Future Building Forum Think Tank Workshop, held in March 2007. The R&D strategies represent the collective input of the Executive Committee members to exploit technological opportunities to save energy in buildings and communities, and remove technical obstacles to market penetration of energy conservation technologies. They apply to residential, commercial, office buildings and community systems, and will impact the building industry in three focus areas of

Continued on page 14

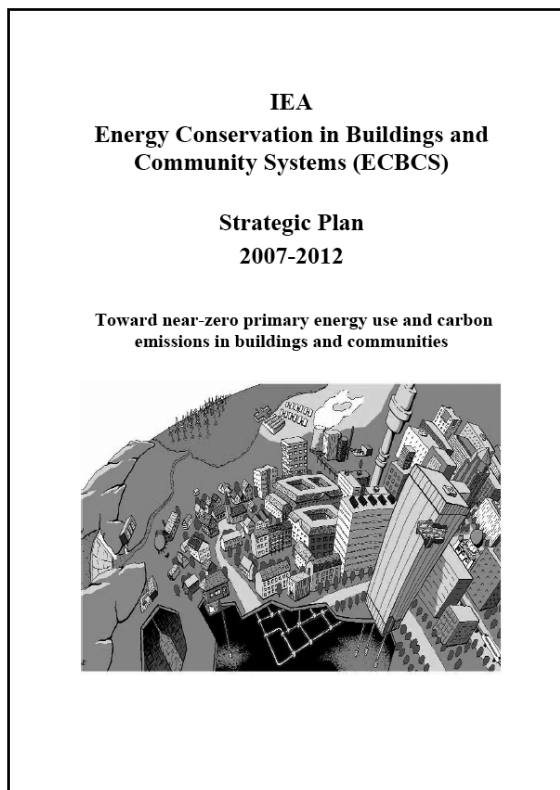

Prefabricated Systems for Low Energy Renovation of Residential Buildings

Mark Zimmermann, Annex 50 Operating Agent

Introduction

The research project ECBCS Annex 50 aims to investigate and promote cost effective low energy renovation strategies for existing buildings. It will focus on typical apartment blocks representing approximately 40% of the European dwelling stock, with the main focus on:

- Reducing primary energy consumption to 30-50 kWh/(m²-year) for heating, cooling and hot water,
- Optimising the integration of solar energy use,
- Increasing living comfort by better use of space, thermal comfort and air quality,
- Ensuring a fast, high quality and cost-effective construction process, based on prefabrication technologies.

The project's working phase started at the beginning of 2007. Eight countries are active in the project: Switzerland (Lead), Austria, Belgium, Czech Republic, France, Netherlands, Portugal, Sweden.

Major improvements are expected regarding standardisation of renovation processes and energy levels for retrofitted buildings. Figure 1 shows the relationship between un-refurbished existing (Swiss) residential buildings and the ambitious energy standard aspired to.

Building typology

The renovation concept is based on standardized renovation modules that have been designed and developed by the research partners in close cooperation with the building industry. In a first step, a building typology has been developed that describes typical renovation needs for European apartment buildings. The building typology describes not only technical issues but also social

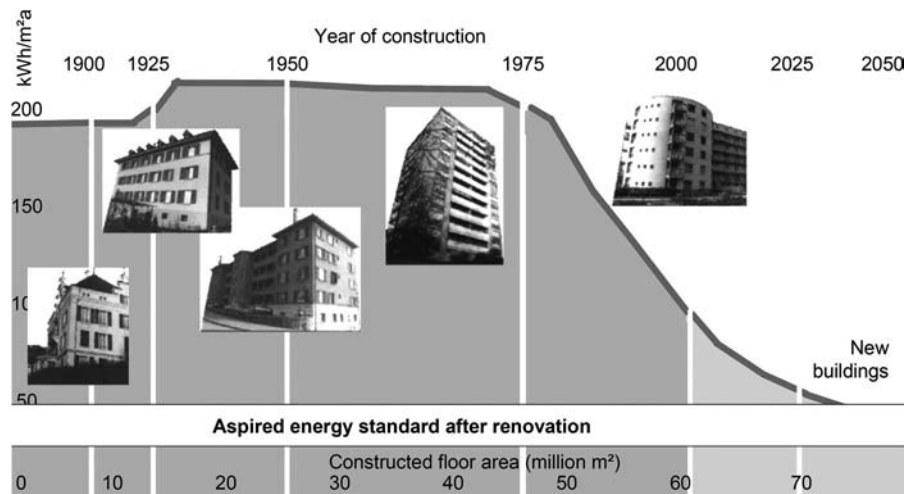

Figure 1: Energy consumption of Swiss residential buildings (Canton of Zurich) for different construction periods and the aspired-to energy standard for buildings constructed 1925 – 1990

and functional aspects. About 150 buildings from all the participating countries have been analysed. A typological profile describing 36 building parameters has been generated for each building and has been used to compare the different buildings.

Renovation modules

A set of representative European building types will be described and used for the development of the modular renovation concept. This will ensure that the renovation modules developed under Annex

50 will have a large multiplication potential. Twelve types of renovation modules are presently being studied and specified (Figure 3). The specifications describe the general requirements for each module, such as thermal properties, geometrical dimensions and tolerances, interface definitions, structural and transportation requirements, fire protection and so on. They ensure that industry partners can develop renovation modules that are well coordinated with the other renovation work.

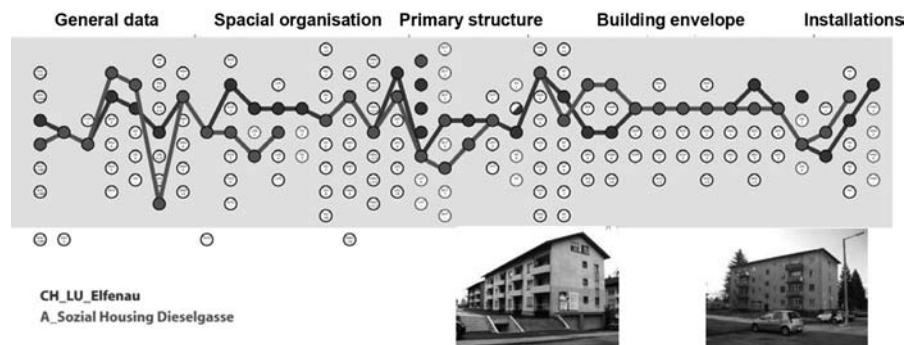

Figure 2: Thirty six building parameters are compared and merged into typical building profiles.

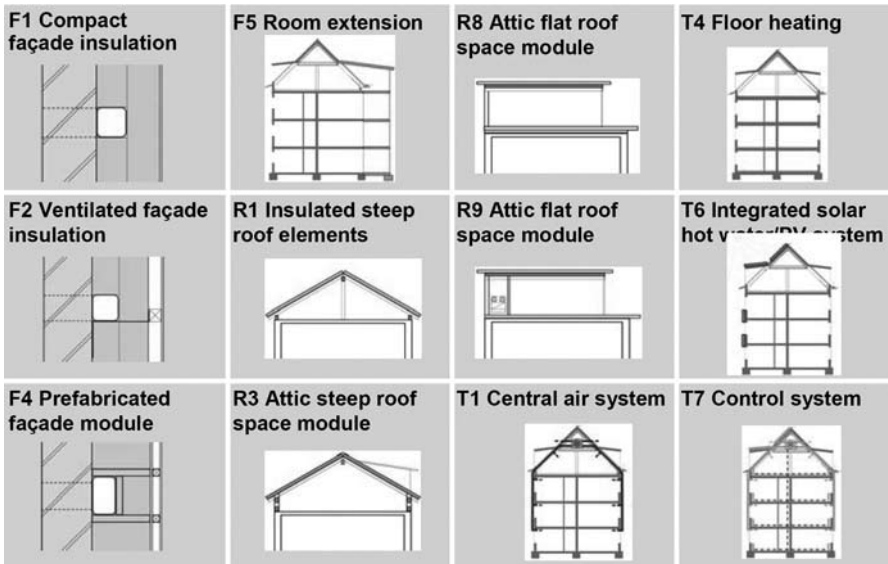

Figure 3: Typology of renovation modules

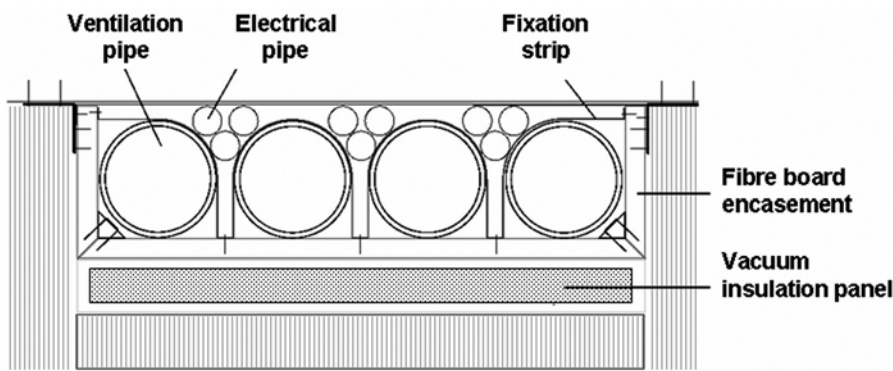

Figure 4: Design study for façade-integrated ventilation system with vacuum insulation for the elimination of thermal bridging

A novelty of Annex 50 is the integration of a ventilation system into the façade construction. Innovative solutions are studied to integrate the piping system into the insulation layer and to apply vacuum insulation to compensate locally for the additional thermal loss. This concept avoids extensive construction work inside the building and makes it possible for the building to be inhabited during refurbishment.

3-D Laser Scanning

One of the challenges specifically related to the prefabrication of large renovation modules is the availability of reliable three-dimensional geometrical data of the buildings. This is not the same problem as with new buildings that are constructed according to construction plans. Existing buildings normally have other dimensions that differ

from those the building plans show, and are often not right-angled as one would expect. A special subtask of the project is therefore dealing with advanced geomatics using laser scanning to obtain an accurate three-dimensional picture of the building (Figure 5). The aim of the project is to apply the most advanced metrology and to develop suitable, cost-effective measurement procedures for building refurbishment.

Annex Products

Annex 50 is presently focussing on the technical development of renovation modules. Most of the participating countries are planning to build demonstration buildings to apply these technologies. The project work will go on until summer 2010 in order to complete the demonstration buildings and to monitor the results achieved. The final documentation will be completed at the end of 2010 when the Annex closes. One of the results will be a *Retrofit Advisor* based on a software tool that will allow us to evaluate the best strategy for the building refurbishment. It will include the results of the building typology, and it will do an economic, environmental and social evaluation of retrofit and reconstruction strategies. Further information is available at www.ecbcs.org/annexes/annex50.htm.



Figure 5: Laser scanning of a demonstration building (left). The measurements show a deformation of a façade of ± 4 cm (right) that can hardly be detected by traditional measurement techniques.

Case Study: Retrofit of a Laboratory Building

Stephane Bertagnolio and Jean Lebrun, ECBCS Annex 48

Environmental concerns and the recent increase in energy costs are opening the door to innovative techniques to provide heating and cooling in buildings. Among these techniques, heat pumps represent an area of growing interest. In many non-residential buildings, an attractive energy saving opportunity consists of using the refrigeration machine for heat production. This can be done by condenser heat recovery whenever there is some simultaneity between heating and cooling demands. When there is no simultaneity, full reversibility needs to be looked for. This is the matter explored in ECBCS Annex

Existing Installation

The first case study is a laboratory building, erected in 2003 near Liege (Belgium). The building has a total floor area of about 6200 m² distributed between offices (1600 m²), laboratories (1300 m²), a technical room (1800 m²), sanitary facilities and small meeting rooms (Figure 6).

The office ventilation is ensured by a CAV Air Handling Unit, blowing about 5,000 m³/h of fresh air, without recirculation. Thermal comfort is ensured in this zone by fifty heating/cooling fan coil units. The laboratories are supplied with 33,000 m³/h of fresh air and are fully

of hygiene. The four AHUs are equipped with glycol heat recovery loops, cooling the extracted air to a minimum temperature of about 12°C in nominal conditions (outdoor temperature: -12°C) to pre-heat the fresh air up to 4°C. The hot water supplying AHU's coils and terminal units' coils is produced by two gas boilers of 300kW each. An R134a air-cooled chiller of 400kW (cooling capacity) ensures chilled water production at 7°C.

Retrofit Opportunity

Numerical models of the building and of the coupled HVAC installation have been developed on EES

Figure 6: Building South Frontage

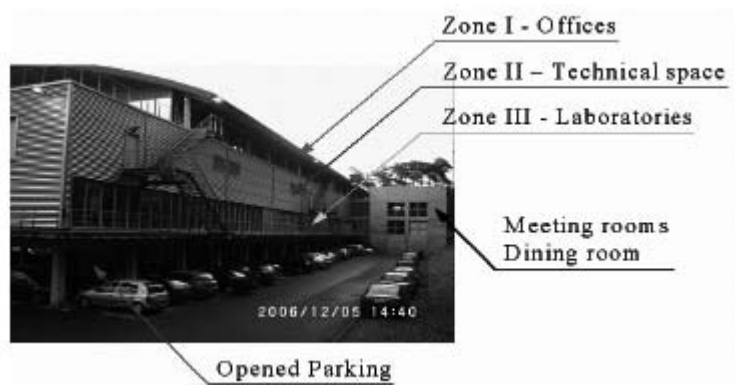

48 project: "Heat Pumping and Reversible Air Conditioning". In this first case study, the possibilities of integrating a heat pumping system into an existing HVAC system are being studied.

conditioned via three CAV AHUs equipped with electrical steam humidifiers. The ventilation flow rate and the temperature and humidity setpoints (23°C/50%) of this second zone are maintained 24 hours a day and seven days a week for reasons

(Engineering Equation Solver, ©F-Chart Software) and used to run annual hourly simulations. Several cases have been considered to assess the different retrofit opportunities.

As mentioned above, two heat

pumping modes are considered:

- Condenser heat recovery (simultaneous heating and cooling demands);
- Reversible heat pumping (non-simultaneous heating and cooling demands).

The building in question is characterized by comparable heating and cooling peak demands. During winter, the building cooling demand is almost or completely null. During summer, the building heating and cooling demands are alternated, according to the day/night periods. However, cooling and heating demands could sometimes be simultaneous in different building zones. So, in the present case, according to the time of the year and the simultaneity of the demands, both heat pumping and condenser heat recovery strategies can be used to satisfy the building demands.

To make it possible, the existing air-cooled chiller has been replaced by a dual-condenser chiller equipped

Figure 7: Heat pumping using the extracted air as heat source

with air and water condensers connected in parallel. A three-way valve ensures the control of the machine and the supply of one or both condensers. The water condenser delivers hot water at a maximum of 55°C.

To enable heat pumping, a heat source is required. It has been decided to use the hot and humid extracted air as the heat source. Indeed, about 33,000 m³/h of hot and humid air are extracted from the laboratories. Downstream of the passive recovery loops, the air temperature does not go below 12°C (RH 90%). Additional air/water coils will be designed to recover the largest part of the available energy to supply the heat pump evaporator. In case of the heat pump capacity being too limited (because of

technical constraints or of heat source capacity limit), the boilers will intervene, as back-boosting devices, to provide the additional heating demand. The existing boilers will remain installed to provide heat to other building zones.

Heating the building with hot water at 55°C could be problematic if the installation has been designed for an 80/60°C temperature regime. Lowering the water supply temperature from 80°C to 55°C could reduce the heating capacity of the heating devices too much (AHU and TU heating coils). It appears that terminal units which

heat exchangers. The changeover technique consists of using these heat exchangers to heat the air as well (in addition to the heating coils already available). The use of a larger heat transfer area permits a decrease in the hot water temperature and an improvement of the performances of the heat pump.

Heat pumping coupled with a changeover technique is generally able to satisfy the heating demand of the building. However interventions of the existing natural gas boilers, as back boosting devices, are sometimes necessary during winter. The economic and environ-

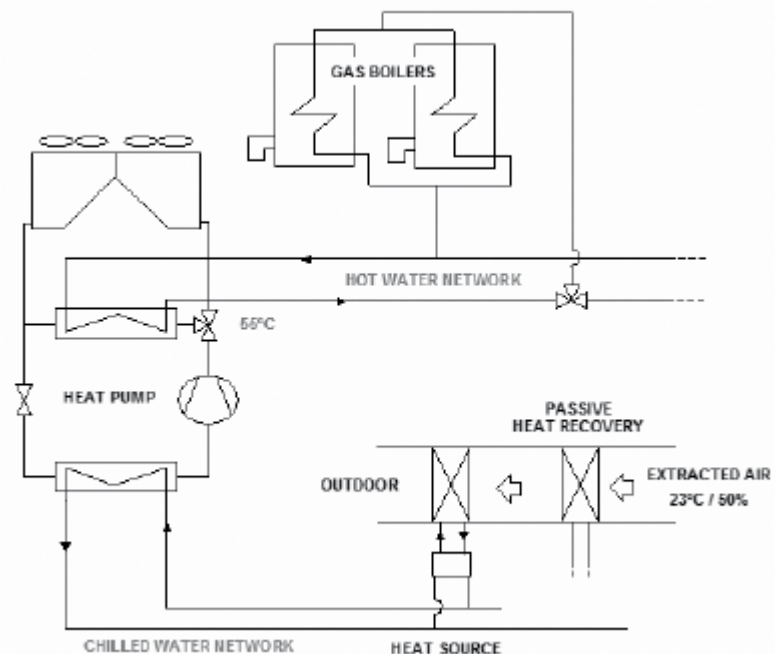

are already installed are sufficiently oversized to function with low temperature hot water most of the time. For AHU coils, a series change over (to maximize the counter-flow effect) will be made on the water circuit. Instead of replacing the heating coils by larger coils offering a larger heat transfer surface, it has been decided to use the cooling coils as secondary heating coils. In the present case, cooling and heating coils are never used simultaneously because there is no dehumidification control. So, during heating periods, the cooling coils constitute large unused

mental studies reveal quite a short payback time (about 7 years) and a significant reduction of natural gas consumption. Also considering the slight increase in electricity consumption, the reduction of total CO₂ emissions is about 18% below current emissions.

Further information

www.ecbcs.org/annexes/annex48.htm

“Trends in National Building Ventilation Markets and Drivers for Change”

Ghent, 18-19 March 2008, Peter Wouters, Annex 5 Operating Agent

This workshop was an initiative of the Air Infiltration and Ventilation Centre (AIVC). It was organised by INIVE EEIG, in collaboration with REHVA (www.rehva.eu) and with the European projects IEE SAVE ASIEPI (www.asiepi.eu) and IEE SAVE BUILDING ADVENT (www.buildingadvent.com).

The aims of the workshop were:

- to inform interested parties (industry, regulators etc.) about the latest changes in national building ventilation markets, with an emphasis not only on indoor air quality and energy issues, but also on airtightness and assessment of innovative systems issues;
- to identify the drivers for change;
- to discuss the status of the issues in a round table with industry representatives.

In order to achieve the objectives, there were well structured country presentations from Belgium, Brazil, Denmark, Finland, France, Germany, Greece, Japan, Korea, Netherlands, Norway, Poland, Portugal, UK and the USA. For each of these countries, a draft of an AIVC Ventilation Information Paper (VIP) was presented during the workshop and a final version is expected to be published over the coming months.

The national presentations answered the following kinds of questions for the workshop participants and to the readers of the VIPs:

- What evolution has there been in the requirements and buildings covered by the national regulations? Are there requirements in terms of ventilation for achieving good indoor air quality, in terms of controls, in terms of stimulating energy consumption reduction, regarding building and/or ductwork airtightness, night time ventilation for passive cooling, thermal/acousti-

cal comfort linked to ventilation? Are there specific requirements regarding buildings with or without major renovation and for ventilation systems for low energy buildings (passive)?

- What are the experiences with compliance? What about the quality of the ventilation systems regarding their life span? Are they well installed and do they receive adequate maintenance? Is the information and training of installers and maintenance companies sufficient?
- What are the major trends in the type of systems used? For instance, what about eco-design of ventilation components?
- Is there a framework for the assessment of the energy performance of innovative ventilation systems in the context of energy performance regulations?

During the last part of the workshop, there were four synthesis sessions on the status and trends of the following topics:

- ventilation and indoor climate control;
- stimulation of energy efficient ventilation;
- building and ductwork airtightness;
- the market uptake of innovative ventilation systems.

Some highlights from these presentations and related discussions are:

- There has clearly been significant evolution during the last decade;
 - Many countries have in recent years implemented or refined calculation procedures and regulations, whereby various aspects of energy efficient ventilation have been taken into account, e.g. building and/or ductwork airtightness, fan energy, heat recovery, demand controlled



ventilation.

- The growing interest in building airtightness has also been remarkable.
 - At the same time, the differences between countries in the handling of indoor air quality concerns are very different:
 - Some countries impose rather strict to very strict requirements whereas other countries don't have any requirements.
 - Some countries pay specific attention to emission control (e.g. Finland) whereas other countries don't pay it any attention at all.
 - Many countries stimulate demand controlled ventilation, whereas it is forbidden in other countries (e.g. in Denmark demand controlled ventilation is not allowed in dwellings).
 - The component-related requirements vary tremendously, e.g. France requires non-closable air supply openings whereas Belgium imposes closable air supply openings.

– Although innovation is the magic word in many political statements, few countries today have an active policy for using building regulations as a tool for the market uptake of innovative ventilation systems. In practice, the regulations are more

often a barrier than a stimulus for innovation.

All the presentations from the workshop are available on the AIVC website (www.aivc.org). The AIVC Ventilation Information Papers

will be made available over the coming months. The summary information papers of the synthesis sessions will also be published by the EPBD Buildings Platform (www.buildingsplatform.eu).

Continued from page 3

The Presentations

Both Executive Committees selected topics of the highest common interest in the fifteen presentations given on the day, as follows:

- “Energy in Belgium”
- “Heat Pumping Technologies in the Current Energy and Environment Contexts”
- “Retrofit Heat Pumps for Buildings”
- “Low Exergy Systems for High Performance Buildings and Communities”
- “Ground Source Heat Pumps – Overcoming Market and Technical Barriers”
- “Effective Commissioning of Existing and Low Energy Buildings”
- “How Efficiently Produced Heat and Cold is Squandered by Inappropriate Control Strategies”
- “Advanced Modelling and Tools for Analysis of Energy Use in Supermarkets”
- “Heat Pumping and Reversible Air Conditioning”
- “Economical Heating and Cooling Systems for Low Energy Houses”
- “Heat Pumps Using Underground Solar Energy Storage”
- “The Simulation of Building-Integrated Fuel Cell and Other Cogeneration Systems”
- “Compact Heat Exchangers in Heat Pumping Equipment”
- “Thermally Driven Heat Pumps; Compact Heat Exchangers in Heat Pumping Equipment”
- “Example of Heat Pumping Retrofit in an Air Conditioned Building”

These papers are available at: www.labohtap.ulg.ac.be

The following ideas have been selected from the presentations and discussions made during the technical day:

- Heat pumping could contribute 6% to the reduction of global CO₂ emissions.
- In many countries, heat pump sales are very well correlated to oil price but not everywhere: for example, in Switzerland, France and Sweden, sales are growing continuously.
- Geothermal systems are becoming more and more popular.
- Heat pumping should be more recognized as a source of (or a means to use) “renewable energy”.
- Heat pump technology is applicable not only to new, but also to existing buildings.
- Three solutions are possible for heat pump retrofitting in old buildings:
 - 1) taking profit from existing low temperature heating systems
 - 2) introducing a high temperature heat pump
 - 3) introducing air to air heat pump
- The seasonal performance factor (SPF) is not the issue, rather the actual reduction of CO₂ emissions.
- Ground heat availability and optimal combination of different production systems should be better addressed at the community level.

- Today there are various ways of using ground heat (classical heat exchangers, direct expansion, CO₂ thermosyphons, etc.
- Combined heating and cooling systems associated with ground heat exchangers are showing promise.
- Drilling is the biggest economic barrier, but the actual lifetime (50 years) should be taken into account.
- Commissioning of HVAC systems should be better supported by the modern technologies available.
- There is currently a lack of information (and even a risk of information loss) on how to operate a building.
- ECBCS should act increasingly in the future as a technology “integrator”.
- This group has three actions to perform:
 - 1) reduce the demand
 - 2) employ renewable energy sources
 - 3) make fossil fuel use as clean as possible
- The present trend is: from components to systems and solutions.
- The heat pump is obviously a key component of the whole system.
- Its use makes a 50% energy saving achievable.
- More efficient cooperation between both (ECBCS and HPP) Implementing Agreements will be surely profitable to the whole community.

Four New Technical Synthesis Reports Available Soon

ECBCS Technical Synthesis Reports aim to provide a concise summary of the research project which has been carried out, in order to highlight its achievements and provide an accessible overview for non-specialists. They are published at the ECBCS website and are free to download. A number of new reports are in the final stages of preparation and will be made available in the next few months.

Forthcoming Technical Synthesis Reports

Daylight in Buildings

A joint project with the IEA Solar Heating and Cooling Programme. The aim was to develop a scientific, engineering and architectural basis to support the effective and economic integration of daylighting concepts into the design of non-residential buildings. The project sought to promote daylight conscious building design saving energy through greater utilisation of natural light while at the same time improving visual comfort and control of solar gains.

The studies focussed on those daylighting systems and strategies which could be applied in new and existing buildings with a high aggregate electricity saving potential such as offices, schools, commercial and institutional buildings. Systems and strategies were tested and performance evaluated through studies in laboratory facilities, by computer simulations, as well as in case study buildings. The performance assessment sought to cover visual, architectural and environmental aspects, including user acceptance of the systems.

The project was divided into four sections: performance evaluation of daylighting systems; daylight responsive lighting control systems; daylighting design tools; and case studies.

Low Exergy Systems for Heating and Cooling

This project aimed to promote the rational use of energy by means of low valued and environmentally sustainable energy sources. It had three goals:

- Investigating the replacement of high valued energy (for example fossil fuels and electricity) with low valued energy sources, and assessing the impact on global resources and the environment.
- Assessing existing technologies and components for low exergy heating and cooling in buildings, in order to enhance the development of new technologies, and to provide the necessary tools for analysis and evaluation of low exergy systems.
- Working out strategic means for the introduction of low exergy solutions in buildings by case studies, design tools and guidelines.

If low exergy design is applied to future buildings and building services, thermal conditioning can be achieved by the least amount of exergy through minimising the temperature difference of the sys-

tem and the room. This can result in maximum savings of high quality exergy sources (e.g. fossil fuels). Low temperature heating and high temperature cooling systems.

Low-exergy concepts and technologies, some commercially available and some under development, fall into the following categories: Surface heating and cooling; heating and cooling generators and distribution; community heating, heat exchangers and thermal storage

Surface heating and cooling

- Floor heating technologies – e.g. embedded coils in slabs; coils in surface layers; hollow core slabs; suspended floors; phase change in floor heating
- Wall heating and cooling technologies – e.g. pipes in surface layers; double walls; dynamic insulation; capillary tubes.
- Ceiling heating and cooling technologies – e.g. radiative panels; ceiling integrated systems; cooling beams; evaporative roof surfaces; ceiling panel cooling by double-roofing with a water spray
- Local heaters - e.g. low

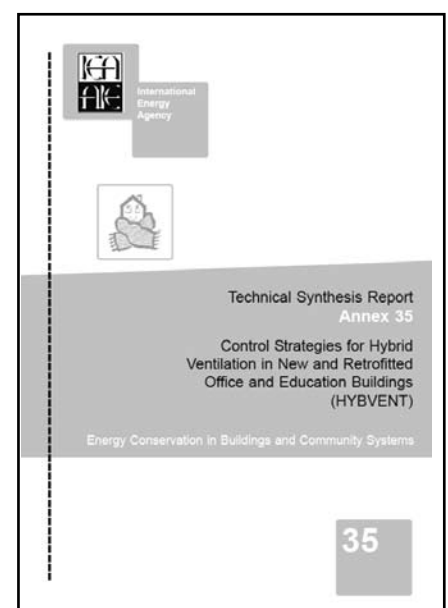
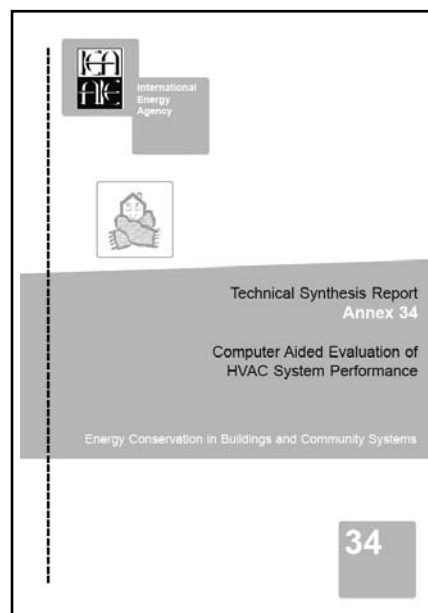

temperatures radiators/ convectors; radiators integrated system; high temperature radiators; base board heaters; transparent insulation

Heating and cooling generators and distribution

- Boiler - condensing boilers, pulsating gas boilers
- Ground heat – pipes in surface layers
- Heat pumps – compressor heat pumps, absorption heat pumps
- Solar collectors – flat plate, evacuated tube, unglazed flat plate
- Combined heat and power – with gas motor, with microturbines, with string motor
- Fuel cells
- Biological systems/Metabolic – bacteria, animals, plants
- Transfer medium – air, water, phase change thermal storage

Community heating, heat exchangers and thermal storage

- Community system – district heating, district cooling
- Air heating and cooling – air to air heat exchangers, water to air heat exchangers, steam/vapour to air heat exchangers, other heat exchangers, passive systems, e.g. atria and solar chimneys

- Thermal storage – seasonal storage, short term storage
- The advantages of low-exergy systems can be seen as follows:-
- Indoor air quality is improved through reduced particles, dust, mites and lower air temperatures.
- Thermal comfort is improved as low-exergy systems tend to provide radiant heat (rather than convection), they avoid sharp temperature gradients and are slower to respond than most traditional high temperature systems and therefore avoid large fluctuations in temperature.
- Energy consumption is reduced as transmission losses and venting losses can be minimised and opportunities to use temperature gains (e.g. solar gains) maximised.
- Other benefits may also arise, such as extra internal space due to the absence of radiators and avoidance of mould growth.

The project analysed 37 case studies of low-exergy buildings demonstrating the very wide range of applications possible for low-exergy systems and the flexibility in the choice of fuel source. The results of the case studies also provide strong evidence that as well as improved thermal comfort, low-exergy systems have many consequential

benefits such as improved indoor air quality and reduced energy consumption.

Solar Sustainable Housing

Examples of high-performance housing already exist across Europe, characterised by high insulation, airtightness and heat recovery mechanical ventilation. The optimisation can be further enhanced with the use of passive or active solar technologies and high-efficiency consumption residual non-renewable energy use. This project explored the many different permutations of these technologies available, together with economic and marketing aspects. The very positive message to be drawn here is that the technologies to provide such high performance homes economically are already in place, and with carefully structured marketing, the uptake is set to increase exponentially. There are already 4,000 so-called 'passive houses' in Europe, and the production has been doubling annually in recent years.

The products of this project include three commercially published books aimed at architects and designers, and online publications and brochures designed to awaken the interest of investors, developers and homebuyers.

The synthesis report aims to explain in a simple way these positive findings, with a view to enthusing architects, developers and potential buyers to design, build and buy solar sustainable homes. Emphasising a holistic approach, it offers a path through the huge and flexible variety of technologies and methods available. Solar sustainable housing has the positive impact of helping to protect the planet, establish healthy and comfortable living, and for developers, the chance to expand into a new and profitable reputation-enhancing area of business.

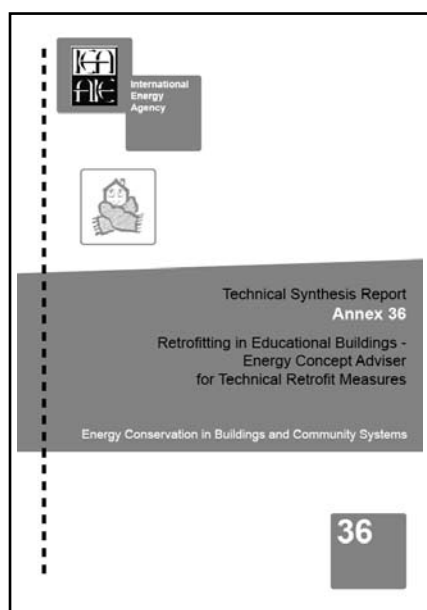
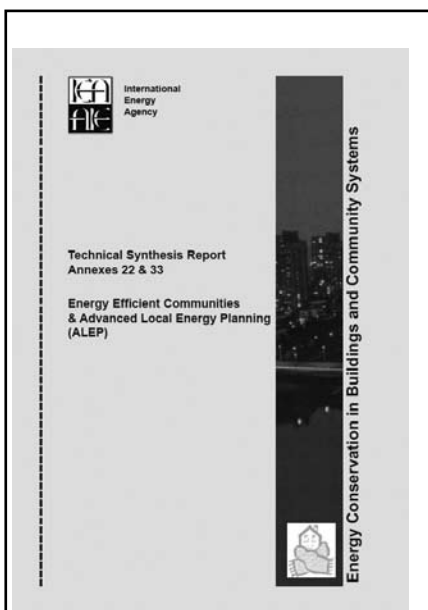

High Performance Thermal Insulation – Vacuum Insulation Panel Properties and Building Applications

High performance insulation systems are becoming increasingly desirable due to several factors:-

- Increasing legal insulation standards for new buildings in many countries
- The expense and inconvenience of insulation thickness, which can reduce space available for living and increases construction costs
- Increasing popularity of low energy building concepts, demanding U-values even lower than regulation.
- Limited space to install extra insulation in existing buildings
- The high importance of thermal insulation in relation to CO2 emission reductions.

For retrofitting existing buildings,

reduced volume high performance thermal insulation is likely to be used in floor heating systems, doors, flat roofs, interior wall insulation, window enlargement, water heaters and ducts.

The main product type investigated in the project was Vacuum Insulation Panels (VIP), which consist of a microporous core material, packed in a gas tight envelope which is evacuated to a pressure of around 0.1 mbar. Their insulation performance is a factor of five to ten times better than that of conventional insulation. Used in buildings, they enable thin, highly insulating construction to be realized for walls, roofs and floors.

Their construction consists of nano-structured materials, extremely fine-structured core materials which are robust in maintaining a vacuum under pressure. Their service life is 30 to 50 years.

The project illustrated a wide selection of reports from practice, showing how the building trade deals with this new insulation system today, the experience gained and the conclusions drawn. As well as presenting recommendation for the practical use of VIP, the report is also able to answer questions regarding the effective insulation values to be expected with today's VIP.

With existing building stocks comprising the vast majority of the sector, around 50% with currently zero insulation (in the EU), the potential value of VIP for retrofitting these buildings cannot be overestimated. As a guide, it is estimated that the energy consumption of the dominating old buildings could be reduced by a factor of three, reducing EU CO2 emissions by about 8%, or the equivalent of the reduction agreed as part of its Kyoto Protocol commitment.

Continued from page 5

R&D activities:

- dissemination,
- decision-making tools and
- building products and systems.

Decision Making

The strategic goal of decision making is to develop methodologies, methods and validated tools for the life cycle decision-making enabling processes to produce high-performance building and community solutions on demand.

Areas of focus:

- Develop performance indicators and criteria for sustainability
- Develop tools for integrated design, construction and management
- Develop life-cycle commissioning methodology and ICT based commissioning tools
- Develop local energy planning tools

Building Products and Systems

The strategic goal of building products and systems is to develop and demonstrate highly resource-efficient new and retrofit / refurbishment building and community solutions, and advanced operating systems for controlling and using them.

Areas of focus:

- Develop solutions for carbon neutral energy production and use
- Design and demonstrate prefabricated and modular energy retrofit solutions
- Develop advanced control systems, sensor networks and user-interfaces

Dissemination

The strategic goal of dissemination is to develop and improve information mechanisms, methods and tools in order to create powerful, environmentally aware end-users

and to create a basis for an attractive environment of new business models.

Areas of focus:

- Improve information mechanisms
- Develop performance information platforms of existing building stocks
- Develop information platforms of best practice business models
- Implement reportive buildings and ratings
- Influence legislation and authorities

Further information

www.ecbcs.org/docs/ECBCS_Strategic_Plan_2007-2012.pdf

ECBCS Executive Committee Members

AUSTRALIA

Mr Colin Blair
Director Building and Utilities
Standards Australia International
286 Sussex Street
P.O. Box 5420
Sydney 2001
Tel: +61 2 8206 6735
Email: colin.blair@standards.org.au

AUSTRIA

Werner Weiss
AEE-Intec
Postfach 142
Feldgasse 19
A-8200 Gleisdorf
Tel: +43 3112 588617
Email: w.weiss@aee.at

BELGIUM

Prof Jean Lebrun
Lab.de Thermodynamique
Université de Liège
Campus du Sart-Tilman, Bâtiment B49
Chemin des Chevreuils, B 4000 Liège
Tel: +32 43 664801
Tel: (Secretariat) +32 43 664800
Email: j.lebrun@ulg.ac.be

CANADA

Dr Morad R Atif (Chairman)
Director, Indoor Environment Research
Program, National Research Council
1500 Montreal Road (M-24)
Ottawa, Ontario K1A 0R6
Tel: +1 613 993 9580
Email: Morad.Atif@nrc-cnrc.gc.ca

CZECH REPUBLIC

Irena Plockova
Ministerstvo prumyslu a obchodu
Na Frantisku 32, 110 15 Praha 1
Tel: +420 224 851 111
Email: plockova@mpo.cz

DENMARK

Mr Lennart Andersen
Programme Manager
The Danish Energy Agency
Ministry of Climate and Energy
Amaliegade 44
DK-1256 Copenhagen K
Tel: +45 3392 6700
Tel: +45 3392 6702
Email: lea@ens.dk

FINLAND

Dr Markku J. Virtanen (Vice Chairman)
VTT Technical Research Centre of Finland
Lämpömiehenkuja 2, Espoo
P.O Box 1000, FI-02044 VTT
FINLAND
Email: markku.virtanen@vtt.fi

FRANCE

Mr Pierre Héran
Bâtiment et Collectivités, Agence de
l'Environnement et de la Maîtrise de l'Energie
Centre de Sophia Antipolis, 06560 Valbonne
Tel: +33 4 93 95 7947
Email: pierre.herant@ademe.fr

GERMANY

Mr Jürgen Gehrman
Forschungszentrum Jülich, Projektträger
PTJ-ERG
Postfach 1913
D 52425 Jülich
Tel: +49 2461 614852
Email: j.gehrmann@fz-juelich.de

GREECE - tba

ISRAEL

Dr. H. Avraham Arbib
Deputy Chief Scientist and Director
Division of R&D
Ministry of National Infrastructures
P O Box 13106
Jerusalem 91130
Tel: +972 2 5316128
Email: aarbib@mni.gov.il

ITALY

Dr Marco Citterio
ENEA SIRE HAB
C.R. Casaccia, Via Anguillarese 301
00060 S. Maria di Galeria
Roma
Tel: + 39 06 3048 3703
Email: citterio@casaccia.enea.it

JAPAN

Dr Takao Sawachi
National Institute for Land and Infrastructure
Management
Ministry of Land, Infrastructure and Transport
Tachihara 1, Tsukuba, Ibaraki, 305-0802
Tel: +81 298 64 4356
Email: sawachi-t92ta@nilim.go.jp

REPUBLIC OF KOREA

Seung-eon Lee
Research Fellow, Building Research Dept.
Korea Institute of Construction Technology
2311, Daehwa-Dong, Ilsan-Gu, Goyang-Si,
Gyeonggi-Do 411-712
Tel: +82-31-910-0343
Email: selee2@kict.re.kr

NETHERLANDS

Mr Piet Heijnen
Program Adviser, Built Environment
SenterNovem, Swentiboldstraat 21
Postbus 17, 6130 AA Sittard
Tel: +31 46 4 202268
Email: P.Heijnen@senternovem.nl

NEW ZEALAND

Mr Michael Donn
School of Architecture
Victoria University of Wellington
PO Box 600, Wellington 1
Tel: +64 4 463 6221
Email: michael.donn@vuw.ac.nz

NORWAY

Jørn Lindstad
Senior Adviser
Program Coordinator Building and
Construction
Division for Innovation
The Research Council of Norway
PO Box 2700, St. Hanshaugen
N-0131 Oslo
NORWAY
Tel: + 47 22 03 72 89
Email: jli@rcn.no

POLAND

Dr. Eng. Beata Majerska-Palubicka
Faculty of Architecture
Silesian University of Technology
Wydział Architektury
ul. Akademicka 7
44-100 Gliwice
Tel: +48 32 237 24 41
Fax: +48 32 237 24 41
beata.majerska-palubicka@polsl.pl

PORTUGAL

Prof. Eduardo Maldonado
Faculdade de Engenharia, Universidade do
Porto, Rua Dr. Roberto Frias
s/n 4200-465 Porto
Tel: +351 22 508 14 00
Email: ebm@fe.up.pt

SWEDEN

Mr Conny Rolén
Formas
Box 1206, Birger Jarls torg 5
S-111 82 Stockholm
Tel: +46 8 775 4030
Email: conny.rolen@formas.se

SWITZERLAND

Mr Andreas Eckmanns
Bereichsleiter Gebäude
Sektion Öffentliche Hand und Gebäude
Bundesamt für Energie BFE
Worblentalstrasse 32
CH-3063 Ittigen
SWITZERLAND
Tel: +41 31 322 54 61
Fax: +41 31 323 25 00
Email: andreas.eckmanns@bfe.admin.ch

TURKEY - tba

UK

Clare Hanmer
Technology Manager, The Carbon Trust
3 Clement's Inn, London WC2A 2AZ
Tel: +44 (0)20 7170 7089
Clare.Hanmer@carbontrust.co.uk

USA

Mr Richard Karney,
Senior Technical Advisor, Office of Building
Technologies, State and Community
Programmes, US Department of Energy
Mail Stop EE-2J
1000 Independence Ave SW
Washington DC 20585
Tel: +1 202 586 9449
Email: richard.karney@ee.doe.gov

ECBCS Operating Agents

IEA Secretariat

Jeppe Bjerg
Energy Analyst
Energy Technology Policy Division
International Energy Agency
9 rue de la Fédération
75739 Paris Cedex 15
FRANCE
Tel: +33 1 40 57 66 77
Email: jeppe.bjerg@iea.org
Web: www.iea.org

5 Air Infiltration and Ventilation Centre

Dr Peter Wouters
INIVE EEIG
Boulevard Poincaré 79
B-1060 Brussels, Belgium
Tel: +32 2 655 7711
Email: aivc@bbri.be

AIVC Steering Group Chairman
Dr Max Sherman
Indoor Air Quality Division,
Building 90, Room 3074,
Lawrence Berkeley National Laboratory
Berkeley, California 94720, USA
Tel: +1 510 486 4022
Email: MHSherman@lbl.gov
Web: www.aivc.org

44 Integrating Environmentally Responsive Elements in Buildings

Prof Per Heiselberg
Indoor Environmental Engineering
Aalborg University
Sohngårdsholmsvej 57
DK-9000 Aalborg, Denmark
Tel: +45 9635 8541
Email: ph@bt.aau.dk
Web: www.ecbcs.org/annexes/annex44.htm

45 Energy-Efficient Future Electric Lighting for Buildings

Prof Liisa Halonen
Helsinki University of Technology
Lighting Laboratory
P.O.Box 3000,
FIN-02015 HUT, Finland
Tel: +358 9 4512418
Email: liisa.halonen@hut.fi
Web: www.ecbcs.org/annexes/annex45.htm

46 Holistic Assessment Toolkit on Energy Efficient Retrofit Measures for Government Buildings

Dr Alexander Zhivov
Energy Branch
US Army Corps of Engineers
ERDC - CERL
2902 Newmark Dr.
Champaign, IL 61826-9005, USA
Tel: +1 217 373 4519
Email: Alexander.M.Zhivov@erdc.usace.army.mil
Web: www.ecbcs.org/annexes/annex46.htm

47 Cost Effective Commissioning of Existing and Low Energy Buildings

Daniel Choinière
Technology Expert, Natural Resources
Canada, CANMET Energy Technology
Centre -Varennes, 1615 Lionel-Boulet
C.P. 4800, Varennes, Qc J3X 1S6
CANADA
Tel: +1 450 652 4874
Email: Daniel.Choiniere@NRCan.gc.ca

Natascha Castro
Mechanical Engineer
National Institute of Standards and
Technology
Mechanical Systems & Controls Group
100 Bureau Drive Stop 8631
Gaithersburg, MD 20899-8631
USA
Tel: +1 301 975 6420
Email: natascha.castro@nist.gov
Web: www.ecbcs.org/annexes/annex47.htm

48 Heat Pumping and Reversible Air Conditioning

Prof Jean Lebrun, Director
Lab.de Thermodynamique
Université de Liège
Campus du Sart-Tilman, Batiment B49
Chemin des Chevreuils
B 4000 Liège, BELGIUM
Tel: +32 43 66 48 01
Tel: (Secretariat) +32 43 66 48 00
Email: j.lebrun@ulg.ac.be
Web: www.ecbcs.org/annexes/annex48.htm

49 Low Exergy Systems for High-Performance Buildings and Communities

Tekn. Dr. Dietrich Schmidt
Fraunhofer-Institute for Building Physics
Project Group Kassel
Gottschalkstraße 28a
D-34127 Kassel
GERMANY
Tel: +49 561 804 1871
Email: dietrich.schmidt@ibp.fraunhofer.de
Web: www.ecbcs.org/annexes/annex49.htm

50 Prefabricated Systems for Low Energy / High Comfort Building Renewal

Mr Mark Zimmermann
EMPA-ZEN
Überlandstrasse 129
CH 8600 Dübendorf
SWITZERLAND
Tel: +41 1 823 4178
Email: mark.zimmermann@empa.ch
Web: www.ecbcs.org/annexes/annex50.htm

51 Energy Efficient Communities

Mr Reinhard Jank,
Volkswohnung GmbH,
Ettlinger-Tor-Platz 2,
76137 Karlsruhe, GERMANY
Tel: +49 721 3506 238
Fax: +49 721 3506 197
Email: reinhard.jank@Volkswohnung.com

52 Towards Net Zero Energy Solar Buildings (NZEBS)

Mr Mark Riley
Buildings and Communities Group
CANMET Energy Technology Centre
Natural Resources Canada
1615 Lionel-Boulet
C.P. 4800 Varennes
Qc J3X 1S6
Tel: +1 450 652 4874
Email: mriley@nrcan.gc.ca

Prepared by
ECBCS Executive Committee Support Services Unit

c/o Faber Maunsell Ltd,
Beaufort House
94/96 Newhall Street, Birmingham B3 1PB
United Kingdom

Printed on 9Lives 80 paper - 80% recycled
and manufactured to ISO 14001 standard

ISSN 1023-5795 (Print version)
ISSN 1754-0585 (Online version)

Tel: +44(0)121 262 1900
Fax: +44(0)121 262 1994
Email: bookshop@ecbcs.org
Web: www.ecbcs.org

Published by Faber Maunsell Ltd on behalf of IEA ECBCS

© Faber Maunsell Ltd 2008